

Bischoff & Bischoff

Instructions for Use

Pyro Light / Pyro Light XL



Enjoy mobility.

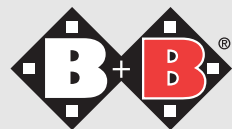

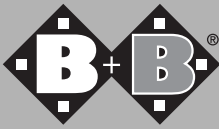
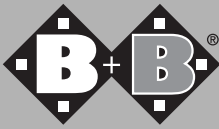

Table of contents

1	Preliminary remark	4
	1.1. Important safety information	
2	Indications	8
3	Purpose	9
4	Declaration of conformity	10
5	Scope of delivery and checking the delivery	11
6	Overview of the wheelchair	13
7	Assembly/Adjustments	15
	7.1. Folding and unfolding	
	7.2. Legrests	
	7.3. Side parts	
	7.4. Seat/Seat height adjustment	
	7.5. Brake	
	7.6. Wheels and tyres	
	7.7. Quick-release axles	
8	Options	23
	8.1. Horizontally adjustable leg legrest	
	8.2. Drum brake	
	8.3. Height-adjustable side parts	
	8.4. Height-adjustable push handles	
9	Accessories	25
	9.1. Tilt protection	
	9.2. Activity tray	
	9.3. Safety belt	

10 Driving	26
11 Technical data	28
12 Transport	30
12.1 Transporting the wheelchair	
12.2 Seat in disabled vehicle	
13 Storage/Shipment	36
14 Repair	36
15 Disposal	37
16 Appendices:	38
Care, hygiene and maintenance guidelines	
Hygiene + risk evaluation	
Maintenance plan	
17 Guarantee certificate	46



1. Preliminary remark

Dear user,

By purchasing your Bischoff & Bischoff folding wheelchair from the Pyro Light Series, you are getting a top German product that sets new standards with its variability.

These operating instructions are to help you become more familiar with the operation and use of the wheelchair.

1.1 Important safety information

In order to avoid toppling and dangerous situations, you should practice safe handling of your new wheelchair on a flat and familiar surface. In such a case, an assisting person is recommended.

- Prior to using the wheelchair, please check whether all parts attached have been fastened properly.
- Never lift the wheelchair by parts that are not fixed firmly (the armrests or legrests).
- Ensure that instantaneous/quick-release axles are positioned correctly in the axle holders, as otherwise there is a danger of injury.
- Please note that the danger of tipping is increased by shifts in weight (e.g. strong upper body movements or overcoming obstacles). The critical obstacle height is 23 mm.
- Steps and larger obstacles may only be crossed with the help of at least two assisting persons. For this, use lifting points 1 and 2 (see overview of the wheelchair). If equipment such as ramps, lifts or step climbing aids are available, these should be used.
- When using on a downward incline, it must be noted that a danger of tipping exists from 8% (5°). It is recommended to use tilt protection.

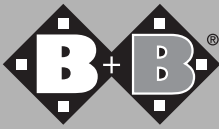

- Avoid running against obstacles (steps, kerbs) without braking or moving down steps.
- Avoid using on uneven, loose surfaces.
- An assisting person should be used if going over obstacles (steps etc.). Use the tip assist (see overview of wheelchair) to tip the wheelchair appropriately.
- When getting into or out of the wheelchair, apply both locking brakes.
- Ensure a sufficient profile depth of your tyres.
- Observe the road traffic regulations when on the road.
- The passive lighting (reflectors) of your wheelchair must always be visible to other road users.
- The locking brake must not be used for braking when the wheelchair is moving.
- When braking at fast speeds or on long downward slopes when using the push rims, fingers and hand surfaces become hot. Caution! Danger of burning!
- We recommend that leather gloves are used for use outdoors. These increase grip and protect fingers and hands from dirt and injury at the same time.

- When transferring between wheelchair and bed, always ensure that:
 - both locking brakes are applied
 - the side part on the side for getting in/out is swung backwards.
 - the foot plates (for getting in/out) are folded upwards, swing inwards/outwards or are removed.

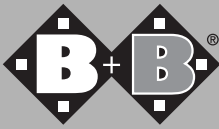

2. Indications

Inability to walk or severe walking disability as a result of:

- paralysis
- loss of limbs
- meromelia/limb deformation
- joint contractures/joint damage
- other ailments

The supply with strengthened wheelchairs is indicated if the body weight of the disabled person is 90 kg and more and a standard wheelchair no longer offers the required safety.

3. Purpose

The wheelchair is produced solely for increasing mobility and for the transport of people with impaired mobility in accordance with the above-mentioned indications.

To note:

We are only able to issue a guarantee if the product is used in accordance with the specified conditions and for the specified purpose.

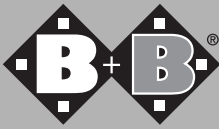

4. Declaration of conformity

B+B declares as manufacturer of the product that the "Pyro Light" and "Pyro Light XL" wheelchairs fully comply with the requirements of directive 93/42/EEC.

5. Scope of delivery and checking the delivery

The scope of delivery in the special carton includes:

- 1 wheelchair, folded
- 1 air pump (only for pneumatic tyres)
- 1 operating instructions
- 1 set of tools (3 Allen keys wrench size 3, 4, 6, 1 cross-head screwdriver, 2 ring spanners wrench size 10, 13)

All B+B wheelchairs are subjected to a proper final in-house inspection and provided with the CE mark.

The B+B wheelchairs are supplied folded in a special carton. Supply, assembly and instruction in use of the wheelchair is carried out by the qualified medical supplies retailer.

If delivered by rail or a forwarding agent, the product is to be checked with regard to transportation damage at once in the presence of the shipper.

If there is any damage, not the following: • Record the facts

- Produce a statement of assignment. All claims from the damage are assigned to the shipper.
- Return of the record of the facts, the consignment note and the statement of assignment to B+B.

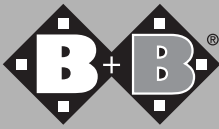

In the case of transport damage...

1. Leave the goods and packaging unchanged and do not use the goods.
2. Register the damage in writing with the transport company as shown below.
3. Then contact our customer service (+49 (0)700/6000 7070)
4. To register claims for compensation with the transport insurance, representatives of the transport company making the delivery must be informed about the damage in good time.

Damage or loss visible externally must be recorded on the accompanying paperwork by the deliverer before accepting the consignment.

Hidden damage only visible after unpacking must be advised to the transport company immediately in writing.

Certain time limits must be adhered to:

- Parcel services and post within 24 hours
- Rail within 7 days
- Shippers within 4 days after receipt of the consignment.

6. Overview of the wheelchair

To make the use of your B+B wheelchair as simple as possible, we have provided detailed illustrations for the written instructions.

The following illustrations should help to identify the names and interaction of the individual elements. (see Fig. 1a and 1b)



Please note the text passages that are identified specially with.



Backrest cover

Armrest cushion

Combined side part

Seat cover

Side part lock

Locking brake knee lever

Lifting point 1

Steering wheel axle

Legrest

Steering wheel

Foot plate

Fig. 1a



Hand push handles

B+B logo

Side part
Drive wheel

External reflectors
Lifting point 2

Tip assist
Push rim



Fig. 1b

7. Assembly/Adjustments

7.1. Folding and unfolding

Delivery

Your new B+B wheelchair is delivered fully assembled and folded in an original B+B carton.

To prevent damage during transport, attachable mounting parts are delivered separately. (Fig. 2)

Unfolding

Position your wheelchair next to you. Tip it towards you until the load is taken off one driving wheel (Fig. 3). Now press with the flat of the hand against the seat tube nearest you to unfold the wheelchair (Fig. 4).



When unfolding, please ensure that your fingers remain on the seat belt. There is otherwise a danger of jamming!

Folding

Position your B+B wheelchair next to you. Tip it by pulling the backrest to you until the weight is taken off the opposite driving wheel.

At the same time, pull the seat cover upwards until the chair is completely folded (Fig. 5).



To prevent injuries, do not hold the wheelchair by the armrest while tilting. If legrests are fitted, the foot plates should first be folded up.



Fig. 2



Fig. 3



Fig. 4



Fig. 5



Fig. 6

7.2. Legrests

Legrests with foot plate

Both legrests are supplied with the foot plates attached. The foot plates on both legrests can be folded upwards.

Attaching legrests

- Hold the legrests on the upper part such that this part points outwards. Operate the handle for the quick-release axle and push the legrests with the guide profile into the hole in the frame (Fig. 6).
- Now the legrest is simply folded forwards and locks automatically into place.



Before moving off, check for firm attachment of the legrests!

Removing the legrests

To transport your wheelchair as compact as possible, you can completely remove the legrests and foot plates (Fig. 7).

- Pull the handle, thus opening the locking device.
- Swing the legrest 90° outwards and pull it upwards.

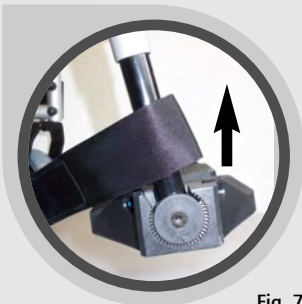

Fig. 7

Swinging away the legrests

To make it as easy as possible to get into and out of your B+B folding wheelchair, you can easily swing the legrests outwards or inwards if needed without having to remove them (Fig. 8).

- Pull the handle. This opens the locking device.
- Now you can swing the legrests outwards or inwards.
- If necessary, fold the foot plates upwards first.

To return to the original position, simply swing the legrest forwards until it locks into place.



When standing up from the wheelchair, under no circumstances stand on the foot plates!

Setting the legrest length

The length of the legrests can be adjusted in 4 20 mm steps up to a total of 80 mm.

- To do so, remove the Allen bolt (4 mm) and set the legrest as required (Fig. 9)

Angle-adjustable foot plates

The angle of the foot plates can be adjusted:

- Unscrew the Allen bolt and adjust the foot plate to the required position by rotating the toothed ring.
- Retighten the Allen bolt



Fig. 8

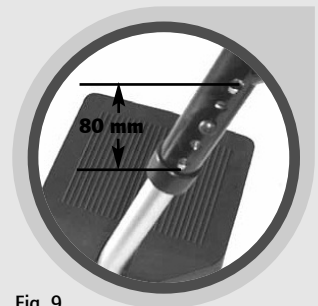

Fig. 9



Fig. 10

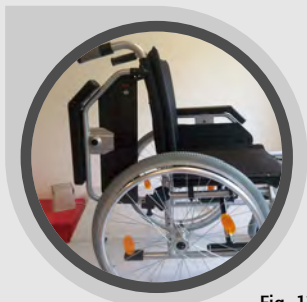

Fig. 11



Fig. 12



Fig. 13

7.3. Side part

In order to be able to get in and out more easily, both side parts and the arm rests can be swung backwards. Operate the locking lever using light finger pressure (Fig. 10) and swing the side part backwards at the same time (Fig. 11).

Do not use the side parts to carry the wheelchair!



To lock the side part, first swing it forwards and allow it to click into place with light pressure on the armrest (Fig. 12).



When moving the side parts, ensure that no items of clothing or other items can become jammed. Before use, check for firm attachment of the side parts!

Combined side parts (only Pyro Light)

The height of the armrest cushions can be adjusted in 6 steps by 70 mm. To do so, press the button and hold while adjusting the height of the armrest (Fig. 13).

The armrest can be adjusted to two lengths (desk/full). To do so, press the button on the side of the armrest cushion and hold while adjusting the angled part to the desk or full position (Fig. 14/15). The armrest locks into position automatically on releasing the button.

7.4. Seat

Seat depth adjustment

You can adjust the seat depth of your wheelchair from 42 cm to 44 cm (Pyro Light) and from 44 cm to 46 cm (Pyro Light XL) .

- If you remove the screws for the seat cover with a screwdriver, you can move the seat tubes 2 cm forwards (Fig. 16).
- After you have set the required seat depth, retighten the screws (Fig.17).



Always ensure that the screws are firmly tightened!

Seat height adjustment

See table "Changing seat height" on page 26

7.5. Brake

Operating the knee lever locking brake (compact brake)

To lock the brake, simply push the brake lever forwards until it locks (Fig. 18). To release the locking brake, simply pull the brake lever backwards (Fig. 18).

Adjusting the knee lever locking brake (compact brake)

If you notice that the braking effect is no longer sufficient or is uneven, proceed as follows:

- With pneumatic tyres, first check the tyre pressure. It must be 300 - 400 kPa (3-4 bar - not necessary for puncture-free tyres).
- Check the tyre profile depth. At the same time, check for even wear of the tyres. If the profile depth in the middle of the tread is <1mm, the tyres must be changed by a specialist retailer.



Fig. 14



Fig. 15

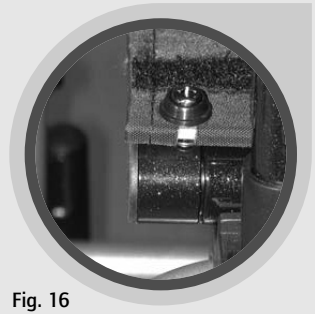

Fig. 16



Fig. 17



Fig. 18



Fig. 19

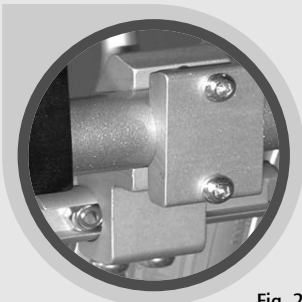

Fig. 20

- Now check the adjustment of the brake. This must be set such that the gap between the tyre tread and the braking bolt with the brake open is 15 mm (Fig.19). The braking bolt must be horizontal, i.e. parallel to the ground surface.
- After unscrewing the two rounded head bolts with 5 mm Allen head on the brake mounting (Fig. 20), you can position the brake correctly.



To ensure optimum braking function, the pneumatic tyres must take pressures of 300 - 400 kPa (3-4 bar)! Not adhering to the required tyre pressure can lead to loss of braking efficiency!

The compact brakes only operate on one driving wheel each!

Ensure that both drive wheels have the same tyre pressure with pneumatic tyres to achieve good directional stability!

After completion of the setting process, retighten the loosened bolts and test the brakes!

In general!

As the brakes are one of the most important items of safety equipment on your wheelchair, the wish for a service braking system for the accompanying person can be fulfilled with the optional drum brake. As well as its use as a locking brake for the wheelchair, the drum brake can be used for braking while moving.

As the drum brake uses a brake shoe that is not applied to the tyres but to the brake drum in the wheel hub, this braking system is largely independent of the tyre state (air pressure) and thus significantly safer. (Drum brake: see options)

7.6. Wheels and tyres

The spoked wheels are attached with a quick-release axle (Ø 12 mm) to the frame with an adapter block (Fig. 21-22). The Pyro Light model comes with quick-release axle as standard. (For quick-release axles, see Section 7.7)



Check for correct attachment of the wheels each time they are attached!

Drive wheels

Rubber tyres with an inner tube or PU tyres (puncture proof, no valve) size 24"x1³/₈" are fitted as standard on your Pyro Light. If they become worn or defective, the authorised specialist retailer should be requested to undertake the repair.



To ensure optimum operating safety of the brakes/wheelchair, the pneumatic tyres must have a pressure of 300-400 kPa (3-4 bar).

Steering wheels

Rubber tyres with an inner tube or puncture proof tyres (without valve) with a diameter of 6" (7" on the Pyro Light XL) are mounted on your Pyro Light as standard. If they become worn or defective, the authorised specialist retailer should be requested to undertake the repair.



To ensure optimum operating safety of the wheelchair, the pneumatic steering wheels must have a tyre pressure of 200 - 250 kPa (2-2.5 bar).



Fig. 21



Fig. 22



Fig. 23



Fig. 24

7.7. Quick-release axles

To achieve significantly easier transport of your wheelchair, the wheels are equipped with quick-release axles as standard:

- Press on the locking button of the quick-release axle with a finger and remove the wheel (Fig. 24).
- When reattaching the wheel, simply push the wheel back into the mount. At the same time, press the locking button.



Ensure when pushing back in that the quick-release axle is pushed! Check after pushing back in that the wheel is firmly attached by pulling it towards you without operating the locking button of the quick-release axle.

7.8. Seat height adjustment

The position of the drive wheel is a criterion for easy, comfortable and pleasant use.

- The drive wheels and steering wheels can be adjusted vertically to allow the seat height to be adjusted.
- The wheelbase can be extended by turning the adapter block by 180°. This increases the stability against tipping backwards (note the assembly instructions)

8. Options

8.1. Horizontally adjustable legrests

To attach, remove, swing away and adjust the legrests and the legrest length, please refer to Section 7.2 Horizontal adjustment functions as follows (see Fig. 25):

- Pull lever backwards
- Bring the legrest into the position required by raising or lowering the support tube for the legrest.
- Release the lever. The legrest locks automatically.

8.2. Drum brake

Operating the drum brake for the accompanying person

To apply selective braking during use, simply pull the brake lever evenly on the right and left as required. To lock the brake, the locking lever is pushed forwards (Fig. 26) while pulling the brake lever. To release the locking brake, simply pull the brake lever briefly. The locking is released automatically (Fig. 26).



Fig. 25



Fig. 26



Fig. 27

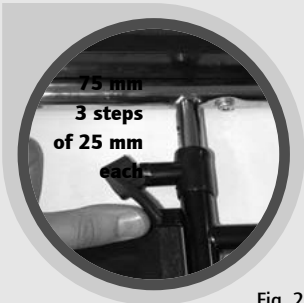

Fig. 28

8.3. Height-adjustable side parts (Pyro Light XL)

Your Pyro Light XL can optionally be equipped with height-adjustable/removable side parts (only full version).

Height adjustment:

- Operate the locking lever to move the armrest to the required position (75 mm, 3 steps of 25 mm, Fig. 28).
- When you reach the position required, release the lever. The locking device operates automatically.
- The height is correct when the upper and lower arm roughly form a right-angle when the lower arm is on the cushion.

8.4. Height-adjustable push handles

Setting of the push handles should only be undertaken by an authorised specialist retailer!

9. Accessories

9.1. Tilt protection/anti-tilt rollers



Always use the anti-tilt mechanism in pairs.

To mount tilt protection, proceed as follows.

- Remove the rubber profiles of the tip assist
- Push the round profile for the tilt protection onto the lower side frame tube.
- Attach the tilt protection with the M6x35 bolt and lock-nut M6 in the hole in the frame provided.

9.2. Activity tray

With combined side parts, put in the full position. With side parts with long arm cushions, the tray is simply pushed onto the armrests from the front with the guides provided (Fig. 30). To remove the activity tray, simply pull it out again.

With desk side parts with armrests, the tray is placed with the guides supplied and attached with star head screws (Fig. 30). To remove the activity tray, first unscrew the star head screws and pull the tray out.



Fig. 29



Fig. 30



Fig. 31

9.3. Safety belt

If required, a safety belt is available as an accessory. This is mounted on the side frame of the wheelchair with the side part either temporarily removed or swung away (Fig. 31). Take the open end of the belt once around the side frame tube and fix it with the belt buckle.

Length adjustment is also carried out with the belt buckle. Adjust the belt length such that the belt sits firmly but does not apply pressure.

10. Driving

Sit in your B+B wheelchair. Make sure you are sitting as far back as possible.

The push rims on the drive wheels are used to move the wheelchair. Practice moving the wheelchair carefully at first until you are familiar with it and the way it behaves.

Wheelchairs have only a limited ability to resist tipping and sliding. Particular care is necessary when braking and moving onto or turning on inclines. Leaning a long way out of the wheelchair increases the danger of tipping. For increased safety, all wheelchairs can be fitted with a safety belt (not standard).

To get over obstacles more easily, the assisting person must position the wheelchair at the correct angle to the obstacle by pressing on the tip assist (Fig. 32).

Before getting in or out, the locking brake must be put on. Use outside of the home should only be undertaken with

sufficient experience. Where possible, somebody should accompany you.



The static stability of the base model is 5° (approx. 8%).

The critical obstacle height for the base model in the most adverse situation (max. weight shift backwards) is 23 mm.

* The critical obstacle height is the height where the centre of gravity (with user) is vertical over the edge of the obstacle. If the user attempts to move forward over the obstacle by driving the drive wheels without shifting the centre of gravity forwards, the wheelchair tips over backwards.

According to STVZO 66/1 (German Road Traffic Act) of 01.01.1981, hand propelled wheelchairs require permanently attached lighting to participate in public road traffic (including on footpaths).

This consists of (passive):

- two red reflectors to the rear
- two amber reflectors on both sides.

If the wheelchair is used after dark, the following are necessary in addition (active):

- one white light forwards
- one red light backwards.

These lights must work from an electrical circuit independent of the movement (batteries) power.



Fig. 32

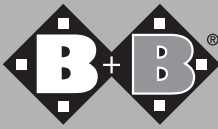

11. Technical data

Seat width:	38, 41, 43, 45, 48, 52 cm * 51, 56 cm **
Seat height adjustment:	integrated adapter plate (Pyro Light) integrated four-hole adapter plate (Pyro Light XL)
Seat height:	42 - 54 cm
Seat depth:	42-44 cm*, 44-46 cm**
Back height:	42 cm
Chassis:	steel
Mounting parts:	plastic-coated aluminium
Folding mechanism:	single cross-frame* double cross-frame**
Drive wheels: (standard)	pneumatic or puncture proof PU tyres 24" x 13/8" on aluminium wheels (other sizes available)
Steering wheels: (standard)	pneumatic, solid or soft rubber tyres 7" x 13/4" (6" soft rubber for Pyro Light) (other sizes available)
Side parts:	combined side parts (desk/full/height-adjustable) * desk or full, only swing-away (optionally height-adjustable) **
Legrests:	removable/swing-away, lower leg length adjustable (optionally horizontally adjustable), foot pla- tes adjustable for angle

Seat and back covers:	high-quality, washable, breathable and easy-care nylon with foam inserts
Braking:	wheel lock (compact brake) (optionally drum brake and brake operation for accompanying person)
Drive wheel axles:	quick-release axle as standard
Colours:	metallic silver metallic blue
Weight:	
"Pyro Light"	16.2 kg:
"Pyro Light XL":	18.5 kg
Max. load:	
"Pyro Light"	125 kg:
"Pyro Light XL":	170 kg
Standard equipment for:	*"Pyro Light" **"Pyro Light XL"

12. Transport

12.1 Transporting the wheelchair

To make the wheelchair as convenient as possible to transport, all detachable parts (footrests, wheels, slot-in accessories) must be removed and the wheelchair folded.

12.2 Seat in disabled vehicle

You can check whether your wheelchair is licensed as a seat in a disabled vehicle by the symbols on the frame (Fig. A and Fig. B).

All wheelchairs authorised by B+B as seats for use in vehicle are tested to ISO 7176-19: 2008.

- The securement points are marked with a symbol (Fig. A). Other attachment points are not authorised by the manufacturer.
- Where possible, use a fixed fitted car seat and its seat-belt system. Stow the folded wheelchair in the boot.
- The person responsible for transportation should be familiar with the current regulations on transportation and use of the disabled vehicle and restraint system.
- 4-point restraint systems anchored to the vehicle must be used to restrain the wheelchair.



Fig. A: Wheelchair suitable as seat in disabled vehicles / anchor points



Fig. B: Wheelchair not suitable as seat in disabled vehicles

- Detachable parts and accessories on the wheelchair, such as trays and bags, should, where possible, be removed and safely stowed in the boot. If attachments are not detachable they must be folded away and secured by the user or adequately padded.
- When used as a seat in a disability vehicle, a 3-point safety belt must always be worn. Other fixation systems and straps may be used in addition.
- If your wheelchair has an adjustable backrest or seat, these must be placed in as vertical a position as possible and the locking mechanism checked.
- Products that have been involved in an accident must be replaced and are no longer licensed to transport people.

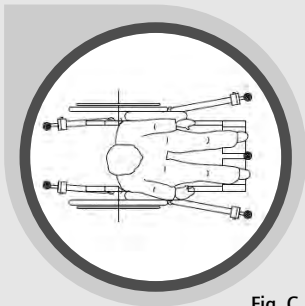

Fig. C

Positioning of wheelchair

- Position the wheelchair facing forwards (Fig. C).

Check whether the straps conform to the angles in Fig. D.

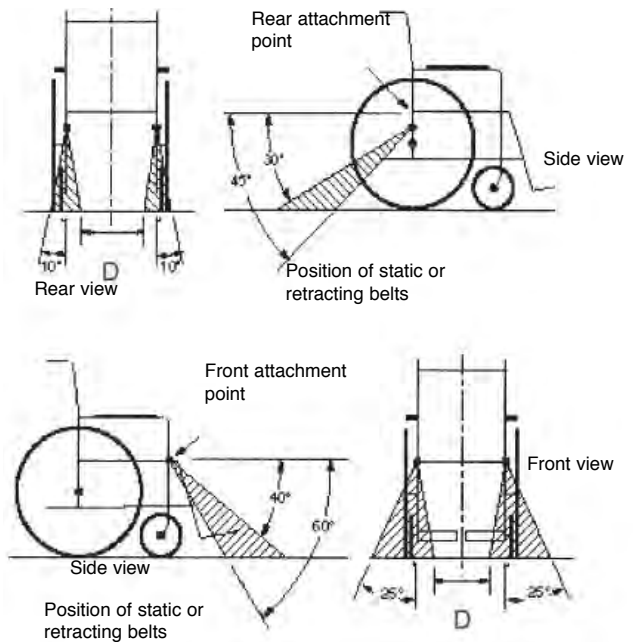

Fig. D

- Stipulated angles and positions of straps from wheelchair to vehicle floor. Front straps should be arranged so that the angle ensures optimum lateral stability ($D = 300\text{mm}$).
- The hatched area indicates the range within which the straps must be attached to the floor!
- Wheelchair must not be placed in front of an active air-bag Deactivate air-bag or have it deactivated!

Attachment to vehicle floor

Rails (Fig. E)

Insert fitting into rail at an angle and then pull in side-ways. Detach the fittings by pulling on the snap ring.

Mono System (Fig. F)

Place mono-fitting flat on the base plate and pull over the base plate. Detach the mono-fittings by pulling down from the base plate.

Attachment to wheelchair

Attachment to the wheelchair may be by securement points (Fig. G) or tie-down system (Fig. H) to the labelled points.

Under no circumstances attach the strap to the footrests or other detachable parts.

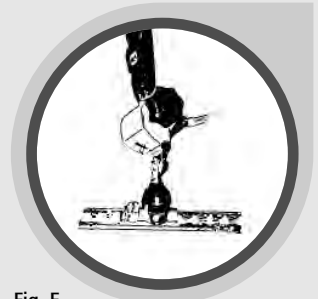

Fig. E

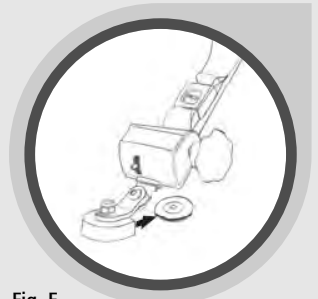

Fig. F

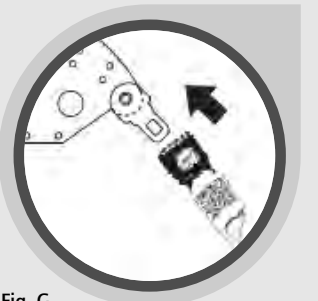

Fig. G

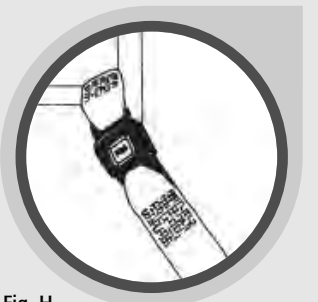

Fig. H

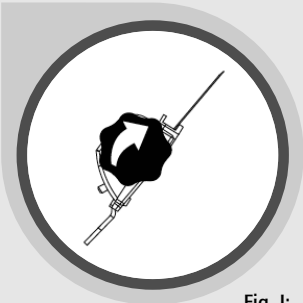

Fig. I:
open

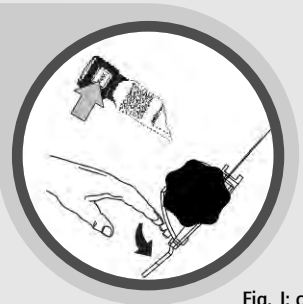

Fig. J: close

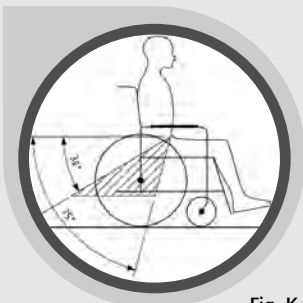

Fig. K

Tensioning and loosening the straps

- Tension using handle (Fig. I)
- Loosening using lever or alternatively by releasing the belt tongue from the belt buckle (Fig. J).

Safety belt

The safety belt must run at an angle of between 30° and 75° to the horizontal (Fig. K), with a larger angle being preferable. It must fit low on the pelvis.

Make sure that the belt lies flat and is not twisted at any point.

The lap belt must be attached on both sides to the rear securement points. To close the lock, insert the tongue into the buckle. It clicks into place. The lock is opened by pressing the large button.

The safety belt should fit firmly but not cut in. To tighten the belt pull on the loose end of the belt. You can further adjust the belt by pushing the clasp forwards in the open position.

The shoulder belt hooks into the lap belt. It must fit close to the body across the pelvis, chest and over the shoulder.

Place the clasp in front of the occupant's body, not on the pelvic bone! The clasp must be positioned in such a way that, in the event of an accident, it cannot be accidentally released by attachments.

Belts must not run across wheelchair attachments such as armrests or wheels! (Fig. L & Fig. M)

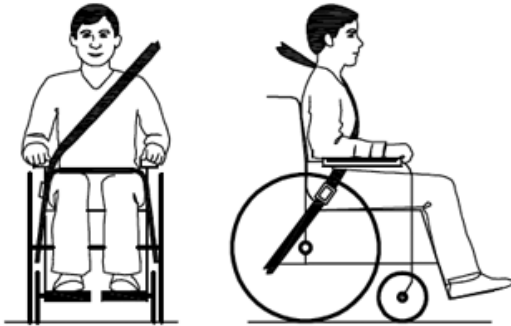

Fig. L

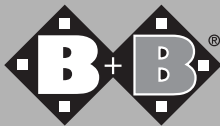

Fig. M

In order to be able to remove the belt quickly in the event of an accident, a seat belt cutter like this (Fig. N) should be kept in every vehicle.



Fig. N



13. Storage/shipment

If the wheelchair is stored or shipped, all removable or non-attached parts, except drive wheels, must be removed and packed individually in suitable containers. The individually packed parts can then be packed together in a larger container. It is recommended to retain the original packaging and to store it for this purpose so that it is available if required. Then your wheelchair is optimally protected against environmental influences during storage or transport

14. Repair

Repairs and maintenance may only be carried out by authorised partners (medical suppliers or specialist retailer). You can find a partner near you by telephoning our customer service:

Tel: + 49 (0)700/6000 7070.

15. Disposal

Even a wheelchair that can no longer be used represents valuable material that can be recycled into the industrial process. Therefore, never throw away your wheelchair for disposal in the household waste, but have it disposed of professionally in an official waste-disposal centre. Your local waste service will be pleased to advise you. The environment will thank you.

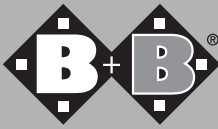

16. Appendices

Care, hygiene and maintenance information for the Bischoff & Bischoff operating instructions

Like all technical products, patient vehicles, mobile walking aids and patient beds, should be subject to a regular check and maintenance by authorised professionals. These checks should primarily ensure the safety of the user. Beyond this, regular care of the product should guarantee proper functioning even after long use. We have prepared some care tips, a hygiene plan and a maintenance table for you below. We hope to have provided a good overview of the most important care, hygiene and maintenance work for your Bischoff & Bischoff product.

a) Care instructions

Cleaning of the seat and back covers can be undertaken with warm water and a sponge or soft brush. For stubborn stains, standard detergent can be added to the water.

Please note: Never use aggressive cleaning agents such as solvents, abrasive agents or hard brush.

Plastic parts can best be cleaned with a standard plastic cleaner. Take note of the product information on the cleaning agent.

Due to the high-quality surface coating, optimum corrosion protection has been achieved. Should the coating be damaged by scratches or similar, you can make good the defective area with a paint pen. Chrome parts are initially wiped with a dry cloth. Dull areas and stubborn dirt can be removed most easily with the appropriate standard cleaning agent.

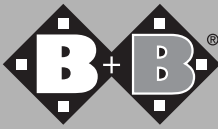

Hygiene plan and risk evaluation of B+B medical products before preparation

In accordance with: the second amendment to the medical products act (2. MPG-ÄndG) of 13 December 2001
here: Article 11 Section 4 Para.2, amendment to the medical devices operator ordinance

Date: 29.04.2005

1. Product

Pyro Light/Pyro Light XL wheelchair

2. Risk level

Non-critical medical product

Medical product that only comes into contact with unbroken skin

3. Hygiene frequency

At least at every change of user

4. Type of process

Wipe disinfection

With standard disinfecting agent in accordance with EN 12720

5. Pre-treatment of the product

Not necessary

6. Disinfection

1. Put on protective gloves before preparing the product
2. Spray the areas to be treated with disinfection agent
3. Wipe dry treated areas with paper towel. Repeat if necessary
4. Dispose of protective gloves and paper towels

7. Special identification

Not necessary

8. Sterilisation

Not necessary

9. Critical process steps, special requirements

*Replacement of the seat and back covers recommended

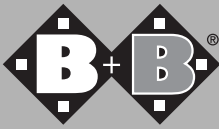

Maintenance table

When

Before each journey

What

Functional check of the brakes

Operate the brake to the full extent of its travel. The braked wheels must not be able to move any more in normal use.

Check for wear in the pressure brake

Move the brake lever sideways. Tightness of all bolts and screws.

Check of the tyre pressure

Standard tyres front: max. 2 - 2.5 bar

Standard tyres rear: max. 3 - 4 bar

Smooth-running tyres: max. 6 - 7.5 bar

Check of the tyre profile

Every 4 weeks (depending on frequency of use)

Oil moving parts

- All moving points of the cross-brace
- Moving parts on the side parts
- Brake lever bearings
- Legrest bearings

Check of bolts and screws for tightness

Please note

Check to be carried out by the user or an assistant.

If brakes are defective, have them repaired by an authorised specialist workshop.

Check to be carried out by the user or an assistant. If the brake play is too great, have it corrected by an authorised specialist workshop.

Check to be carried out by the user or an assistant. Use a tyre pressure gauge.

Caution!

Tyre pressures that are too low have a negative effect on braking behaviour.

Visual check by the user. With worn-out tyre treads or damage to a tyre, have them replaced by an authorised specialist workshop.

To be carried out by the user or an assistant. Before oiling, clean old oil from the parts first. Remove excess oil.

Check to be carried out by the user or an assistant.

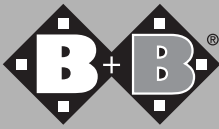

Maintenance table

When

Every 6 months (depending on frequency of use)

What

Checks

- Cleanliness
- General condition

Please note

Take note of the care and hygiene information. In the event of any defects, have the necessary repair work carried out only by authorised specialist workshops, as only these are trained in the necessary work and generally have sufficient trained personnel.

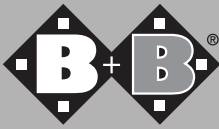

16. Guarantee certificate

This warranty covers all defects in the wheelchair that are shown to be caused by material or production defects.

In the case of complaints, please return the product together with the warranty certificate completely filled in. We provide a guarantee of 5 years on the frame and folding back for our folding wheelchairs in the Pyro Light series, whereas we assume a warranty of 2 years on all other mounting parts.

Caution!

Non-observance of the instruction manual as well as servicing not carried out properly and in particular technical modifications and additions (fittings) without the approval of Bischoff & Bischoff result in both the warranty and the product liability in general lapsing.

In case of queries, please contact the B+B Customer Service at phone no. +49 (0)700/6000 7070.

Warranty certificate

(Please note our general business terms and conditions)

Model: Pyro Light/ Pyro Light XL

Model No:

Serial number:*

(to be filled in by the specialist retailer)

Specialist retailer:

Date and stamp

*Information plates can be found on the side frame

Bischoff & Bischoff GmbH

Becker-Goering-Strasse 13 • D-76307 Karlsbad

Tel.: +49 700/6000 7070 • Fax: +49 700/6000 8080

www.bischoff-bischoff.com

info@bischoff-bischoff.de

